

INSTRUCTIONS

10' x 10' Canopy Tent with Full Wall and Half Walls



Includes:
Tent Frame
4 Steel Pole Pieces
Carrying Case with Wheels
Canopy Graphic
Full Wall Graphic
Half Wall Graphics



1
Place tent frame in center of final place. Remove strap and have two people stand on opposite sides, grasping the outer legs. Lift off of ground and step backwards, stopping when about 1/4 expanded.



2
Place tent graphic over frame. DO NOT attach the fastener in the corners.



3
Expand the frame out fully by having each person stand on opposite sides, grasping the outer legs, lift up and step backwards at the same time until tent is fully opened.



4
Engage the auto slider at each corner by pushing up with one hand while holding down top of leg with the other hand. Snap button will engage in groove. Repeat on all other legs. Attach the fastener in the corners of the graphic.



5
Lift two adjacent outer legs and pull out the inner legs until you reach the snap locks. Repeat on all legs. Raise or level the tent using adjacent holes found near bottom of each leg.



IMPORTANT:
Windy Conditions - Stake or use weight bags.
Heavy Wind - Take tent down.
Wet Fabric - Let tent dry before closing.
Storage - Store in case when not in use.
Rain - Do not leave shelter unattended.



This product is for outdoor promotional use only and should not be left out in extreme weather conditions. Please use common sense guidelines and do not display this product outdoors when extreme winds or storms may be present.

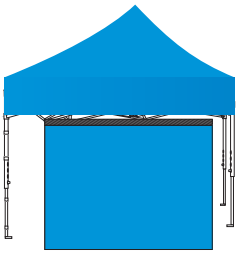

6

Pick up the full wall.

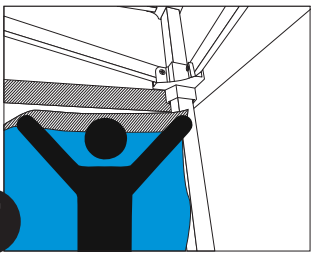

7

Match the fastener of the full wall with the canopy.

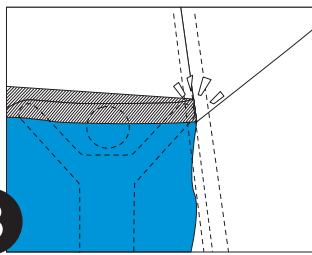

8

Attach the fastener on the edge of the full wall to the fastener on the canopy.

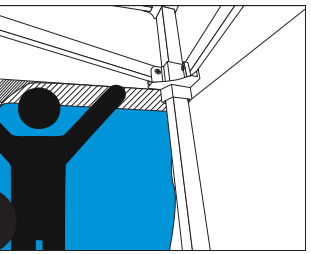

9

Continue attaching the fastener all the way to the end until the full wall is totally adhered to the canopy.

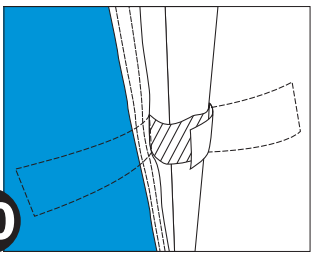

10

Attach the fastener around each leg on either side of the full wall.

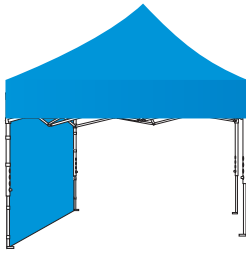

11

If your tent has multiple full walls, attach remaining full walls following the same instructions (steps 6-10).

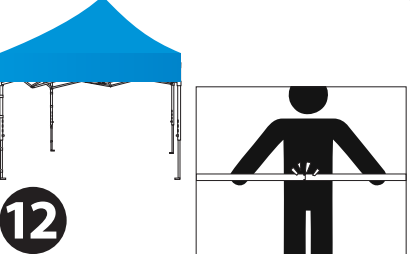

12

Attach the connection parts to the frame. Connect the two steel connection bars.

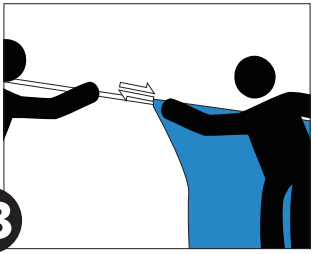

13

Slide the steel connection bar through the pole sleeve of the half wall.

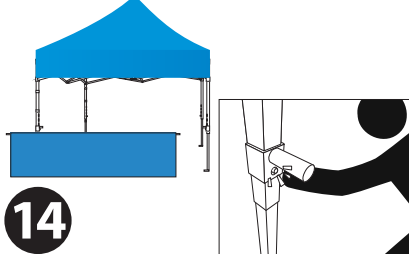

14

Align the connection bar with the hole of the parts.

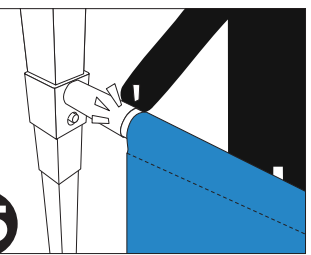

15

Insert both ends into the connection parts.

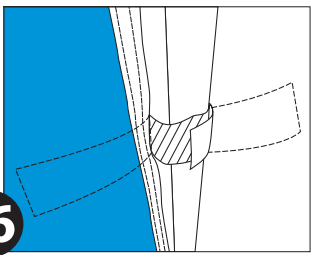

16

Attach the fastener around each leg on either side of the half wall.

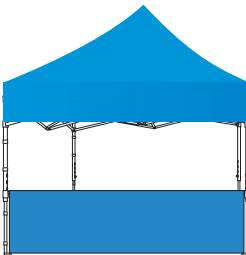

17

Connect the second half wall following the same instructions (steps 12-16).